

**Real 75 Ohm BNC connectors for HDTV Broadcast Applications**  
**Low profile (4mm) right angle PCB mounting with Pathfinder™ Light Pipe Feature**

**Features**

- Real 75 Ohm BNC Connector
- Designed for HD SDV applications
- Low profile allows higher wiring densities
- RoHS Compliant
- Pathfinder™ Light Pipe Feature aids port identification.

**General Description**

BNC, female, low profile, right angle PCB mounting 75 ohm connector. Unique geometry design and specialist materials ensure Real 75 ohm 3G SDI performance.

**Applications**

It is particularly suitable for the broadcast industry for use in HDTV, Serial Video applications where Real 75 ohm connectivity is essential. With a centre line of 4mm above the board, its low profile permits closer packing densities of daughter boards, which allows reduction in the bulk of routing and switching equipment.

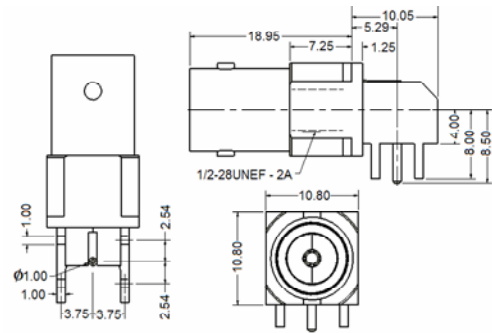

Specification	
Electrical	
Impedance	75 Ohm
Frequency Range	0 – 3.0 GHz
Working Voltage	500 V <sub>rms</sub>
Dielectric Withstanding Voltage	1500 V <sub>rms</sub>
Reflection Factor (VSWR)	1.06 (Max) DC-1.5GHz 1.33 (Max) 1.5 GHz—3.0 GHz
Contact Resistance	Centre contact 1.5 m ohm Outer contact 1.0 m ohm
Insulation Resistance	> 5000 Meg Ohm
*Materials	
Centre Pin	Phosphor Bronze / 10µ " Au
Metal Parts	Brass / Nickel
Insulators	TPX

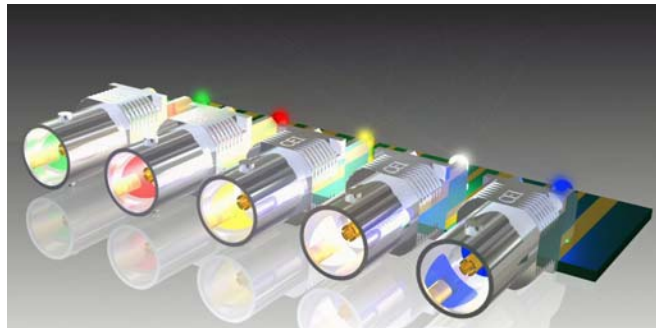

Innovative construction and insulator materials, create a “light pipe” to transmit light from the back of the connector to the front. By using different colours the function and status of each port can be clearly indicated. With the use of self monitoring circuitry it is even possible to indicate failures to the operator.

C-SX-069

\* Other materials such as Gold Plating are available to customer requirement.

Return Loss Graph

(measurements include PCB mounting)

- Return loss @ 3.0 GHz -17.0 db max
- Return loss @ 1.5 GHz -31.0 db max

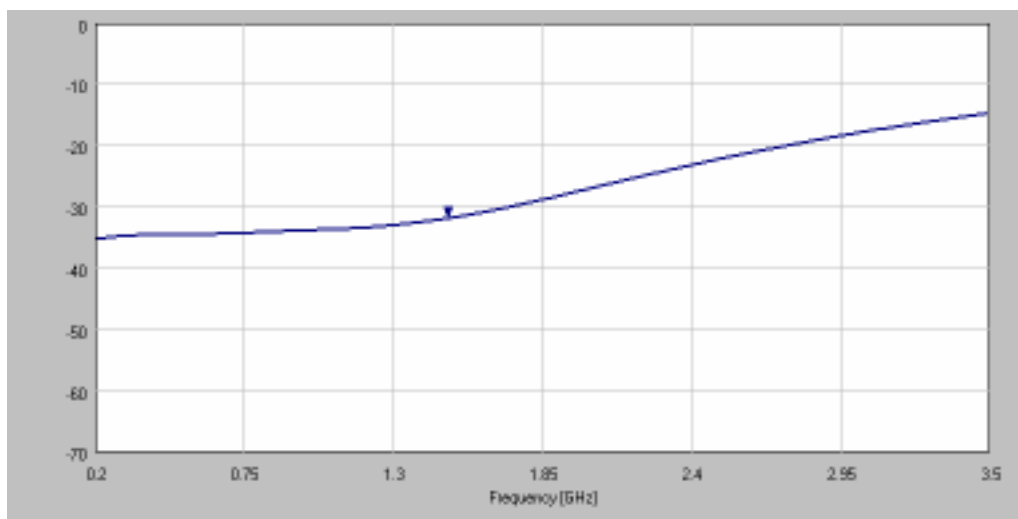

For more details contact our applications engineers on: Tel: 01223 860041 Fax: 01223 863625  
 Email: [technical@cambridgeconnectors.com](mailto:technical@cambridgeconnectors.com) Web site [www.cambridgeconnectors.com](http://www.cambridgeconnectors.com)